

N 50, CEILING COOKER HOOD, 90 CM, STAINLESS
STEEL
I95CAQ6NOB



A



Flush with the ceiling, the stylish integrated ceiling hood leaves room for an open and clear kitchen

- ✓ Cooktop-based Hood Control – Adjust your hood’s extraction level and lighting.
- ✓ Dimmer Function – dim the LED light conveniently with the button on the remote control
- ✓ Remote Control – comfortably control the ceiling hood with a remote
- ✓ Efficient Drive Motor – Quiet and energy-efficient hood motor for a calmer kitchen.
- ✓ Intensive speed setting: increases the extraction rate when the steam gets intense

Z50XXPOX0	Long Life odor filter (replacement)
Z52JCC1N6	Clean Air Plus recirc. kit external inox
Z52JCC1W6	Clean Air Plus recirc. kit external white
Z52JCD0N0	Long Life recirc. kit external inox
Z52JCD0W0	Long Life recirc. kit external white
Z53XXB1X6	Clean Air Plus odor filter (replacement)

Typology:	Island/Ceiling
Length electrical supply cord:	130.0 cm
Min. required niche size for installation (HxWxD):	299mm x 888.0mm x 487mm mm
Minimum distance above an electric hob:	650 mm
Minimum distance above a gas hob:	650 mm
Net weight:	22.2 kg
Type of control:	Electronic
Number of speed settings:	3-stage + 2 intensive
Maximum output air extraction:	459 m ³ /h
Boost position output recirculating:	565.0 m ³ /h
Maximum output recirculating air:	422 m ³ /h
Boost position air extraction:	798 m ³ /h
Maximum Air flow:	459 m ³ /h
Number of lights:	4
Noise level:	56 dB(A) re 1pW
Diameter of air outlet:	150 mm
Grease filter material:	Washable stainless steel
EAN code:	4242004235705
Connection Rating:	174 W
Voltage:	220-240 V
Frequency:	50; 60 Hz
Plug type:	GB plug
Installation typology:	Island
Delay Shut off modes:	10 min



N 50, CEILING COOKER HOOD, 90 CM, STAINLESS
STEEL
I95CAQ6NOB

Key performance features:

- Energy Efficiency Class: A (at a range of energy efficiency classes from A+++ to D)
- Extraction rate according to EN 61591 \varnothing 15 cm:
- max. Normal use 458m³/h
- Intensive 798 m³/h
- Noise max. Normal Level: Noise, max. speed in normal us: 56 dB dB*

Special features

- Hob-Hood control (with Wi-Fi enabled hob)
- Remote Monitoring and Control for connected home appliances and operation via smartphone or tablet (only in countries where Home Connect service is available)
- The Home Connect functionality can be extended by integrating numerous applications from external cooperation partners (partnerships)
- Voice Control enabled via popular voice assistants (only in countries where this service is available)
- Interval function: available via Home Connect
- Silence function: available via Home Connect

Features

- 3 power levels and 2 intensive settings
- Infrared remote control
- LED display
- Twin channel high performance fan motor
- Efficient BLDC technology
- 4 x 3W LED lights
- softLight with dimmer function
- Interval operation
- Automatic after running (Automatic after running (10 minutes))
- Automatic intensive revert (6mins)
- 2 metal grease filter cassettes
- Saturation indicator for metal and charcoal filter
- easy to clean Inner frame
- Rim ventilation

Design

- Installation: Ceiling
- Rotatable motor: possible to position the air outlet on all four sides
- Stainless steel filter cover, metal grease filter
- Electronic controls

Performance/technical information

- Suitable for ducted extraction and recirculation
- For recirculated extraction CleanAir recirculating kit (accessory) needed
- Extraction rate according to EN 61591 max. 798 m³/h
- Noise level according to EN 60704-3 and EN 60704-2-13 at max. normal use exhaust air: 56 dB(A) re 1 pW
- Noise level according to EN 60704-3 and EN 60704-2-13 exhaust

air:

- Max. normal use: 56dB(A) re 1 pW
- Intensive: 68 dB(A) re 1 pW
- Noise level according to EN 60704-3 and EN 60704-2-13 at maximum normal setting: extraction rate: 56 dB (A) re 1pW
- With the Clean Air Plus recirculation kit (available as optional accessory) your appliances reaches:
- Extraction rate in recirculation mode: Max. normal use: 422m³/h
- Intensive: 565m³/h
- Noise level in recirculation mode with Clean Air Plus odor filter : Max. normal use: 63dB(A) re 1 pW
- Intensive: 69dB(A) re 1 pW
- Power rating: 174 W
- Light Intensity: 659 lux
- Colour Temperature: 3500 K
- Electrical cable length 1.3 m
- Diameter pipe \varnothing 150 mm (\varnothing 150 mm enclosed)
- Dimensions exhaust air (HxWxD): 300-300 x 900 x 500 mm
- Blower Efficiency Class: A*
- Lighting Efficiency Class: A*
- Grease Filtering Efficiency Class: E*
- Average Energy Consumption: 34 kWh/year*

Optional accessories

- Recirculating kit Z50XXP0X0

* In accordance with the EU-Regulation No 65/2014

N 50, CEILING COOKER HOOD, 90 CM, STAINLESS
STEEL
I95CAQ6NOB

The fan outlet can be turned
in all four directions

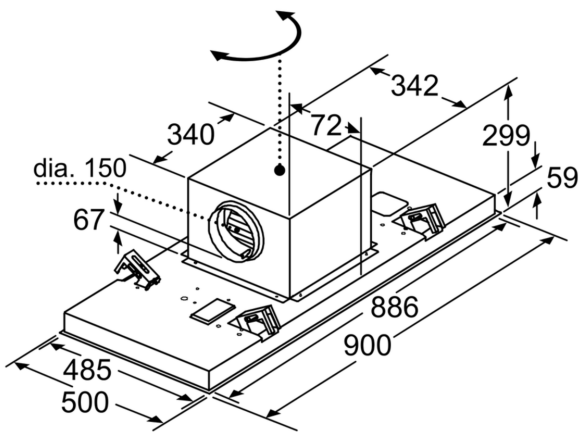

measurements in mm

measurements in mm
Air extraction

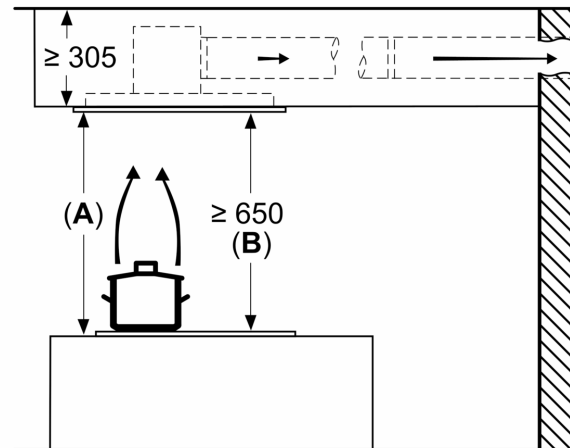

A: Optimum performance 700-1500
B: From upper edge of pan support

measurements in mm
Air recirculation

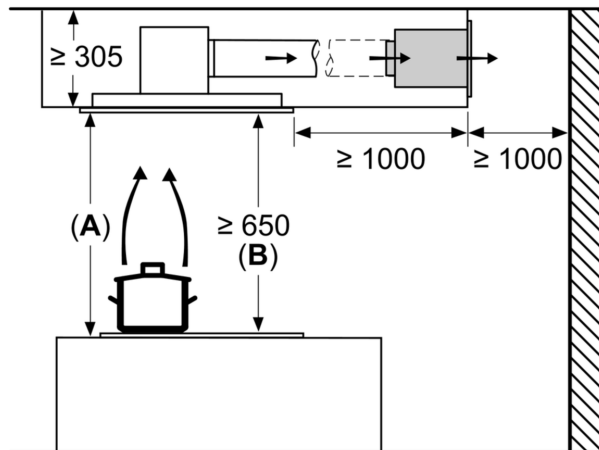

A: Optimum performance 700-1500
B: From upper edge of pan support

measurements in mm
Air recirculation

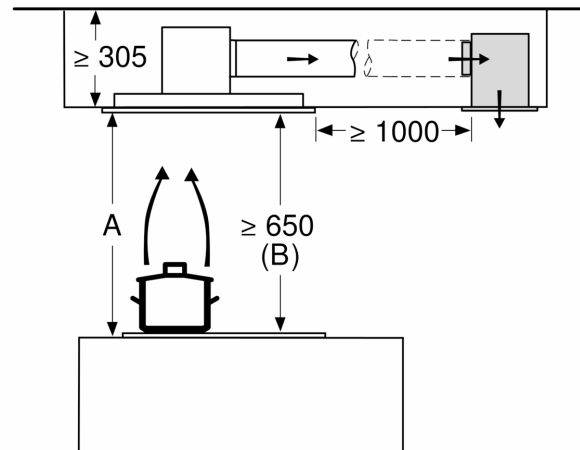

A: Optimum performance 700-1500
B: From upper edge of pan support

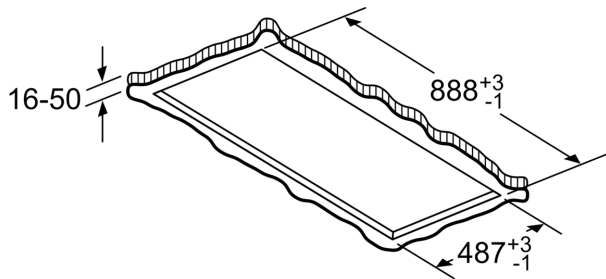

Never fit directly onto plasterboard or similar lightweight construction materials of the suspended ceiling. A suitable substructure is required that is securely fixed to the concrete ceiling.

measurements in mm